

Normal
Cold water impart the mixed layer

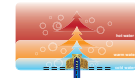

With Fairwater Sleeve
Cold Water can be marshalled effectively creating 20% more hot water output

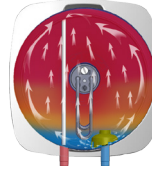
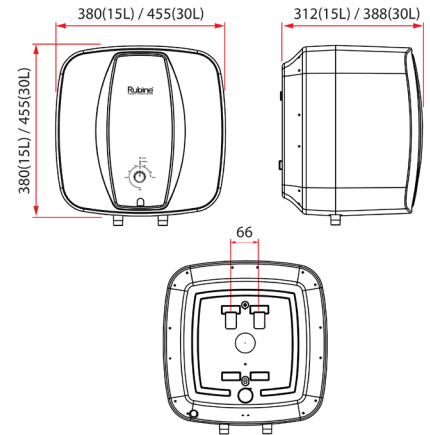

Arch Analogue water heater has a contemporary design. This square-shaped water heater comes in 2 capacities – 15 litres and 30 litres. Beside the standard features in every water heater, it is also equipped with an innovative built-in Fairwater sleeve - a device that produces 20% more hot water and save more energy. Coupled with a SAPPHIRE heating element and inner tank coating, it provides hot water quickly at point of use and a 5 & 7 year warranty respectively. Fast & save, it is the best seller in its category.

* Measured in Millimeters (mm)

* Product dimension is for reference only.



Global Standard For Antibacterial Efficacy
Achieves global standard for antibacterial efficacy that keep the product safe and reliable by suppressing the growth of bacteria.



Fairwater Sleeve
Cold water is marshalled effectively resulting in 20% more hot water output rate.



Sapphire Enamelling Tank
European Enamel Technology extends tank life.



Overall Polyurethane Foam
Keeps the water warm by minimise heat loss. Save 30% more energy.



Sapphire Enamelling Heating Element
Perform best even under high temperature and pressure conditions.



Independent Thermo Cut-out
Independent thermo cut-out protects water heater from overheating.



Thicker Magnesium Anode
27% thicker magnesium anode ensures a longer tank life.



5 Warranty
5 years warranty for heating element.



7 Warranty
7 years warranty for inner tank.

Product Information

Model	RWH-AR15A / RWH-AR30A
Capacity	15L / 30L
Rated Power	2500W
Rated Voltage	220~240V
Rated Frequency	50Hz/60Hz
Heating Time ($\Delta T=35^{\circ}C$)	0h 15min / 0h 30min
Max. Working Temperature	75°C
Max. Working Pressure	0.8MPa
Net Weight	9.29kg / 13.52kg
Colour	White
Safety Mark	150462-11 / 150463-11
Waterproof IP Rating	IPX4
Package Included	Water Heater + Pressure Relief Valve + Mounting Hardware
Warranty (T&C's Apply)	1 Year Parts + Service / 5 Years Heating Element / 7 Years Inner Tank